

RUT STEEL SHELVING ASSEMBLY INSTRUCTIONS

Important: Please follow instructions carefully when assembling this product

Parts List

Starter Units

	Qty
Upright Frame	2
Shelf	6
Magiclip (per Shelf)	4
Bolts and Nuts (Back Panel)	10
Bolts and Nuts (per Upright)	2

Extension Units

	Qty
Upright Frame	1
Shelf	6
Magiclip (per Shelf)	4
Bolts and Nuts (Back Panel)	10
Bolts and Nuts (per Upright)	2
Joining Strip	1

Important: Please contact your Unirack if any parts are missing or damaged before assembly.

Safety Information

- Two people are required for safe assembly
- Install shelving on a level and secure surface. Avoid soft surfaces like asphalt or tarmac.
- We recommend the use of floors fixings in commercial installations
- Chipboard decks not suitable for external use
- For maximum load per shelf please refer to your invoice
- Never climb on shelving

Shelf Width	Shelf Load Capacity
900 mm	90 kg
1200 mm	80 kg

STEP 1

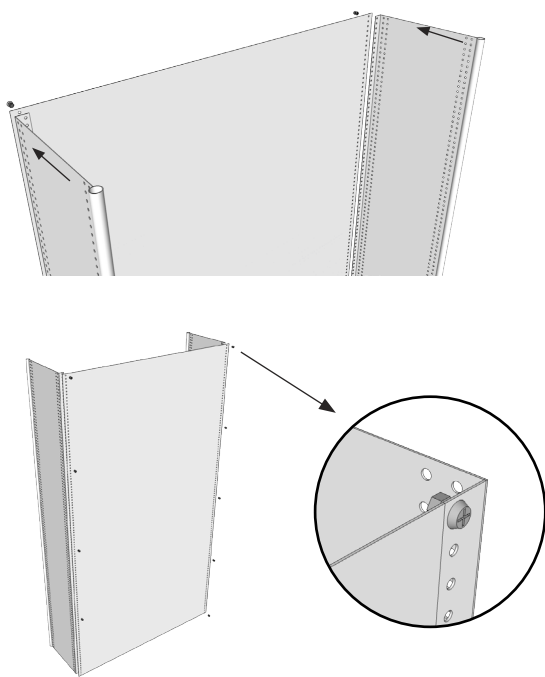

Commence assembly by placing a back panel flat on the floor. Fit an upright to left hand side of back panel by sliding 25mm return on rear edge of upright under back.

STEP 2

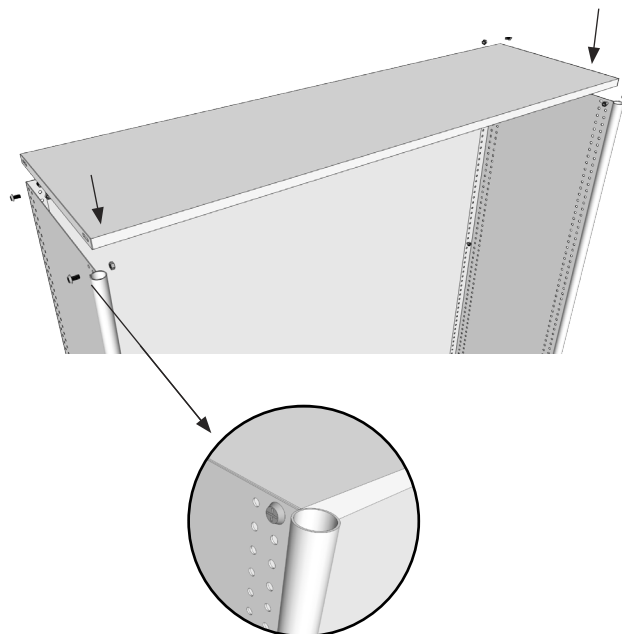

Attached top panel. Secure using bolts and nuts at 350mm intervals. Nuts to be inside of uprights.



STEP 3

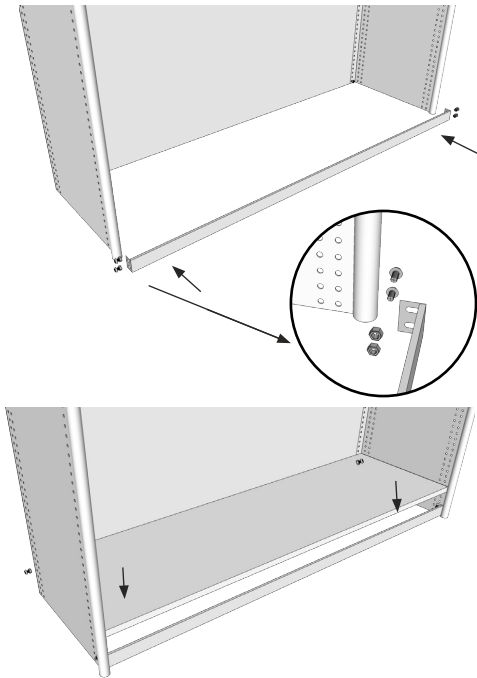

Attached bottom panel. Secure using bolts and nuts. Nuts to be on inside of uprights.

STEP 4

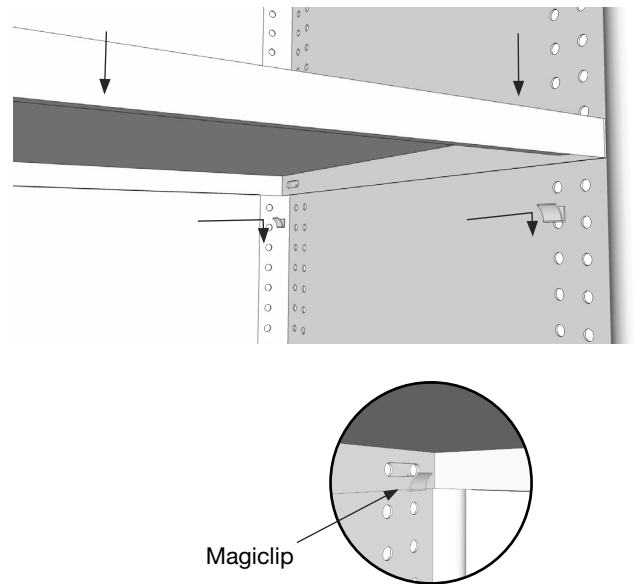

Having formed the shelving bay(s) the next step is to fit the remaining shelves into their respective positions starting from the bottom. Use 'Magiclips' for the shelves.

STEP 5

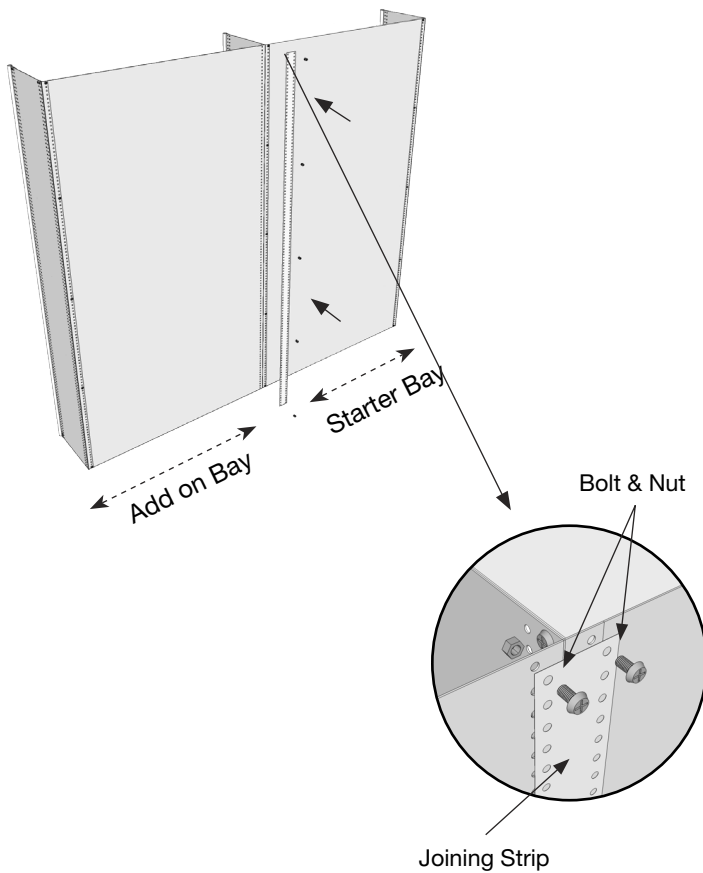

For the Add on Bay, attached an upright to left hand side of back panel (See step 1). Then fit the joining strip at the back of the panel and secure using bolts and nuts.

STEP 6



Repeat step 2 to 4 and just make sure to secure the panel and shelves using the bolts and nuts.