

MEDIUM DUTY CANTILEVER RACKING ASSEMBLY INSTRUCTIONS

Important: Please follow instructions carefully when assembling this product

Parts List

Note : This is for the assembly of a Single Bay Unit with 3 levels (CLM-3612-3-S)

Starter Units

	Qty
Upright Frame	2
Cross Beams	3
Arms	6
Arm Locking Pins	6
Base Frame	2
End Stoppers	6
Beam Locking Pins	6
Nuts and Bolts (M10 x 25mm)	8

Important: Please contact your Unirack if any parts are missing or damaged before assembly.

Safety Information

- Two people are required for safe assembly
- Install on a hard level surface, do not install on a soft surface like asphalt
- Floor fixing must be installed securing the frame to the floor
- For maximum load per shelf please refer to your invoice
- Never climb on cantilever racking

UNDERSTANDING THE PARTS

- | | | |
|------------------|---------------------|-------------------|
| 1. Arm | 4. Cross Beam | 7. Arm Safety Pin |
| 2. Base Frame | 5. End Stopper | |
| 3. Upright Frame | 6. Beam Locking Pin | |

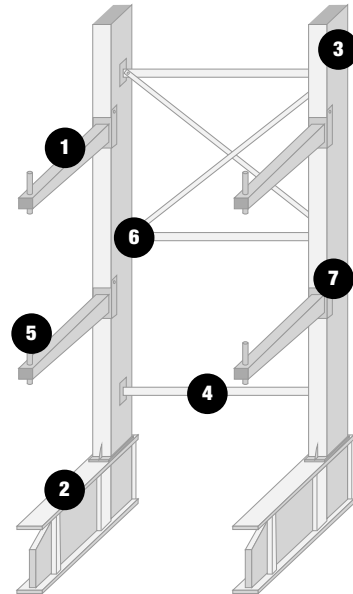

STEP 1

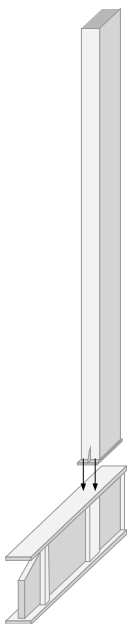

Attached the base frame to the upright frame to secure the base frame to the upright frame using the nuts and bolts (M10 x 25mm) provided.

STEP 2

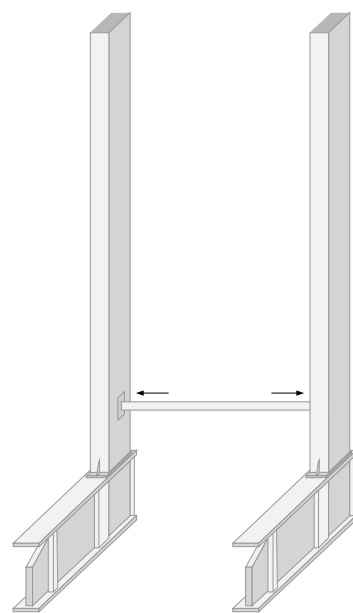

Stand both uprights & attach lower front cross beam. (make sure the beam locking pin is securely in place)



STEP 3

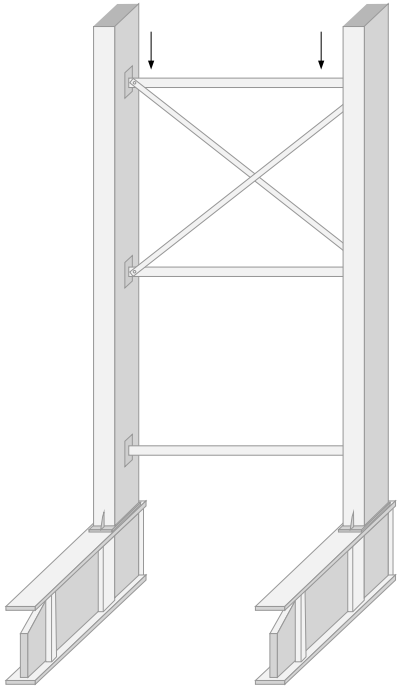

Attach the top cross beams (front & back).
(make sure the beam locking pin is securely in place)

STEP 4

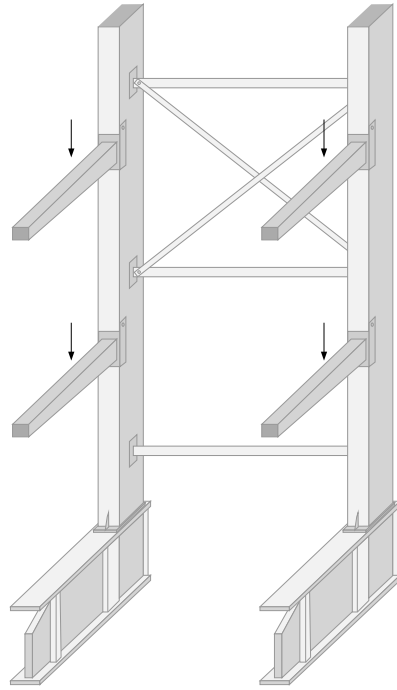

Attach the arms at the desired heights using the arm fixing & arm safety pins provided.

STEP 5

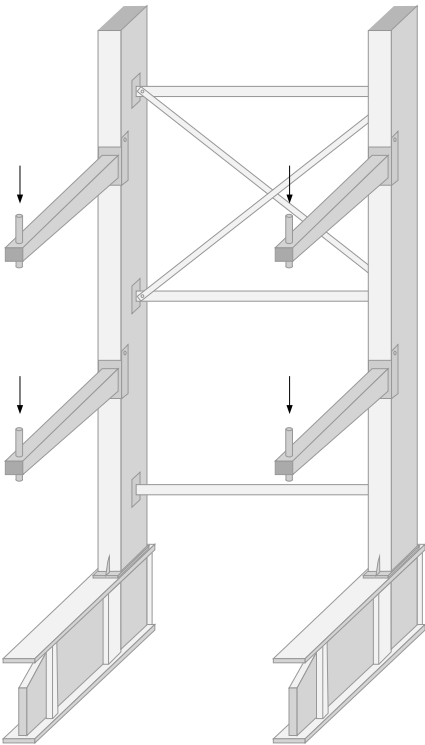

Place end stopper's in each arm.

STEP 6

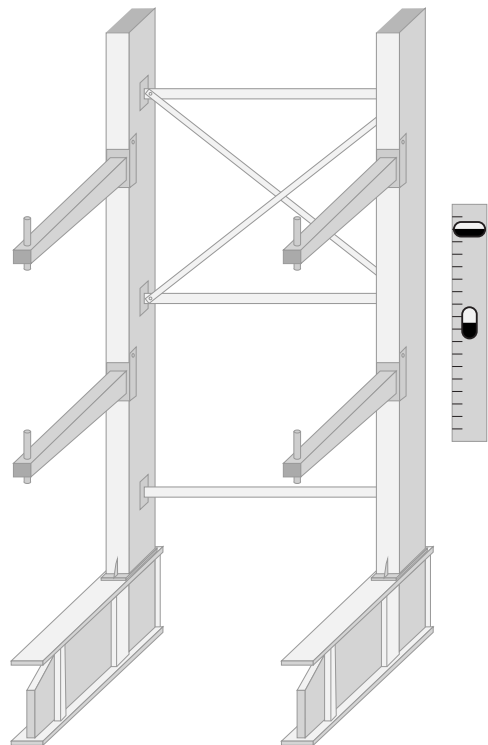

Make sure the frame is level and square, secure the base to the floor with the provided dyna bolts or suitable anchors.

