

## LONGSPAN WORKBENCH ASSEMBLY INSTRUCTIONS

Important: Please follow instructions carefully when assembling this product

### Parts List

#### Standard Workbench

	Qty
Upright Frame (Supplied Assembled)	2
Shelf Beams	4
Beam Locking Pins	8
Particleboard	2

#### Undershelf (Optional)

	Qty
Option 1: Galvanised Shelves	Varies by Width
Option 2: Wire Decks	Varies by Width

#### With Wheels (Optional)

	Qty
Wheels	4

Important: Please contact your Unirack if any parts are missing or damaged before assembly.

### Safety Information

- Two people are required for safe assembly
- Install shelving on a level and secure surface. Avoid soft surfaces like asphalt or tarmac.
- We recommend the use of floors fixings in commercial installations
- Chipboard decks not suitable for external use
- For maximum load per shelf please refer to your invoice
- Never climb on shelving

Beam Width	Load Capacity
900 mm	815 kg
1200 mm	793 kg
1500 mm	635 kg
1800 mm	529 kg
2000 mm	471 kg
2400 mm	327 kg
2700 mm	258 kg
3000 mm	209 kg

### STEP 1

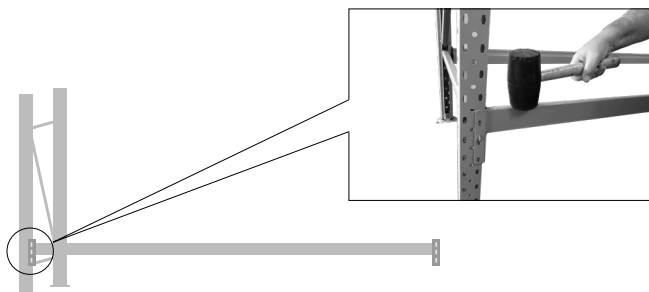

While one person is holding a frame in position, insert the first shelf beam into the frame at the lowest position required. Tap the beam into place near the joint with a rubber mallet. (see diagram).

### STEP 2



Join the shelf beam to the other frame at the same height. Count the number of slots to make sure they are the same at both ends. Tap into place with a rubber mallet as in step 1.

### STEP 3

Repeat steps 1 and 2 to install the other shelf beams. Count the number of slots to make sure the gaps are equal between beams.



## STEP 4

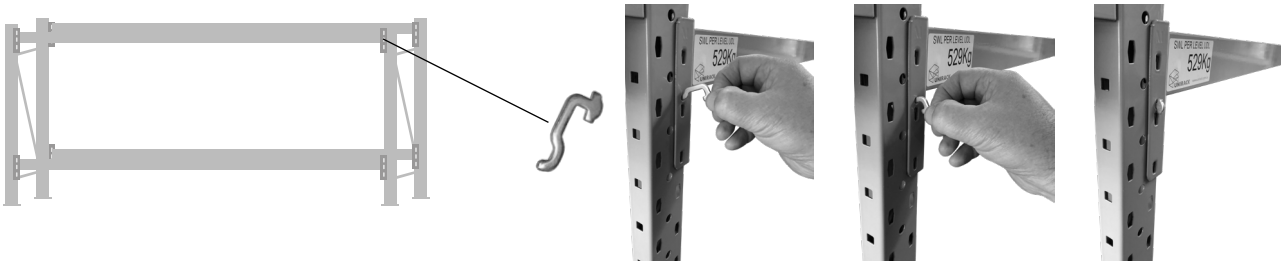

To ensure beams stay securely in place, you must install a beam locking pin into each end of every beam used (every shelf level requires 4 locking pins). Once the beam is located at the correct level and firmly inserted into the tapered post holes, the small hole in the beam indicated below will line up with a matching hole in the post. This will allow the 'S' shaped locking pin to be inserted (thin end first) until the head stops against the beam.

## STEP 5

With Undersheff (Timber, Wire and Galvanised)

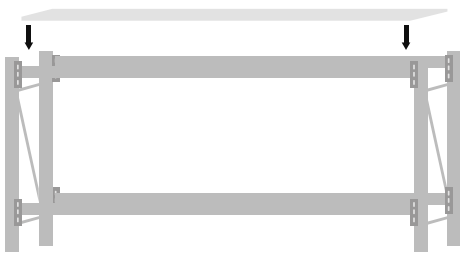

Starting at the upper level, place the particleboard onto the top inner lip of each pair of beams as shown in the diagram.

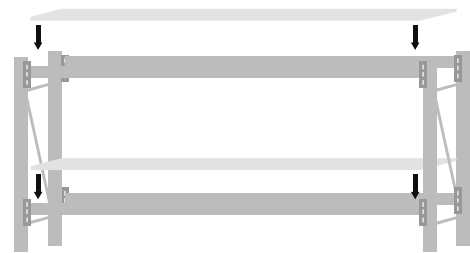

Place the particleboard, wire decks or galvanised shelves onto the top inner lip of each pair of beams as shown in the diagram

## STEP 6

With Wheels

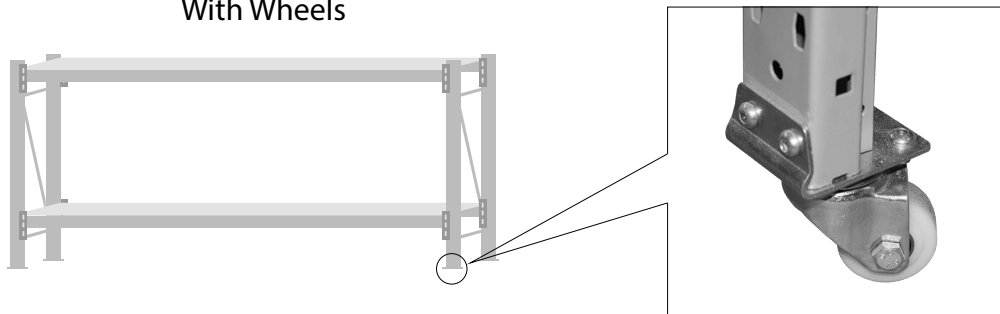

If required, fix frames to the floor through the hole in each foot with appropriate floor fixings (expansion bolts for concrete or screws for wood). Fixings are an optional accessory and not supplied as standard.

## STEP 7



Add the Unirack load rating stickers to each bay.

